

# STÛV 21:

---

**SPECIFICATIONS &  
MANUFACTURER  
INSTALLATION  
GUIDE**

**stûv**

LE FEU ESSENTIEL

# 1. PRELIMINARY INSTALL INFORMATIONS

In relation to the installation and use of this appliance, the installer and the user should strictly adhere to local and national regulations as well as Australian & New Zealand Standards AS/NZS 2918:2001. They should also follow the instructions detailed in the Stuv 21 installation and user manual. Safe operation of the fireplace is directly dependent thereon. The liability of the manufacturer can neither be retained nor assured following failure of installation or incorrect use which is not compliant with AS/NZS 2918:2001.

As each installation is different, a qualified and licensed trades professional should take all required preliminary precautions depending on the technical elements inherent to each job.

In-observance of the assembly instructions in conjunction with AS/NZS 2918:2001 entails the liability of the person who carries it out.

Fireplace structure and finishes shall be to your own design providing the exact and minimum dimensions are maintained.

The floor must have adequate strength to support the fireplace. N.B. Timber floors may require additional reinforcing.

Construction of the fireplace structure from floor to ceiling shall be: solid brick (110mm minimum), Silca 250KM board (40mm), stone (100mm minimum) or Hebel aerated blocks (150mm minimum).

When installed on a combustible floor surface the Stuv 21 firebox must be fitted on a raised platform (height 150mm minimum) constructed of non combustible materials.

As a result of faulty assembly, use of parts or additional components not supplied by the manufacturer/distributor, and/or modifying of the appliance or components will result in inferior or unsafe operation. Should this occur the manufacturer/distributor bears no liability, and will result in a null and void product warranty.

**stuv**  
LE FEU ESSENTIEL

# 2. SPECIFICATIONS

## SINGLE SIDED MODELS WITH ZERO CLEARANCE CASING - DIMENSIONS (mm)

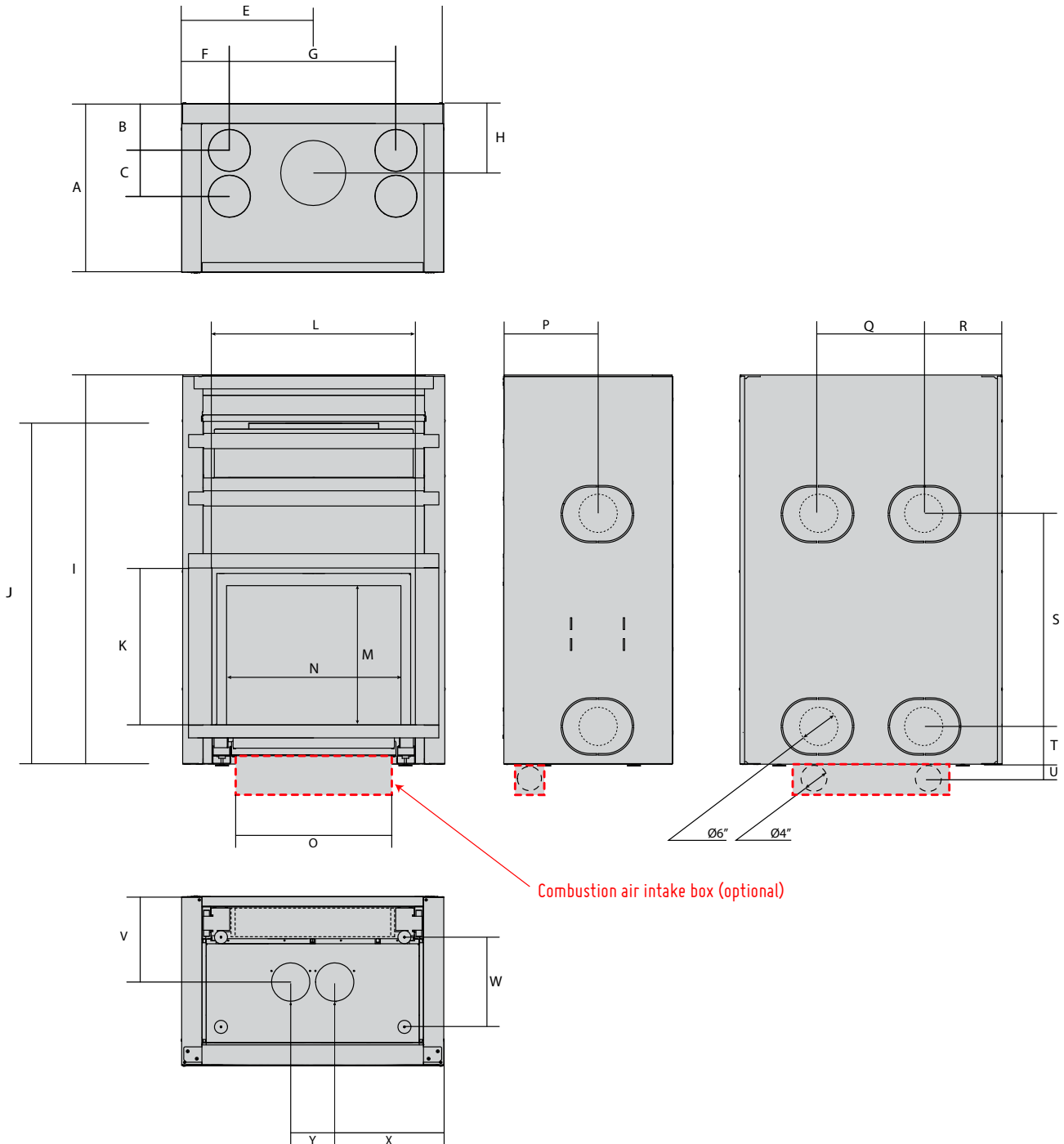

Combustion air intake box (optional)

# 2. SPECIFICATIONS

## SINGLE SIDED MODELS WITH ZERO CLEARANCE CASING - DIMENSIONS (mm)

|   | STUV 21 / 95 SF | STUV 21 / 105 SF | STUV 21 / 125 SF | STUV 21 / 135 SF |
|---|-----------------|------------------|------------------|------------------|
| A | 699             | 610              | 679              | 610              |
| B | 210             | 165              | 200              | 162              |
| C | 178             | 171              | 200              | 171              |
| D | 1108            | 1210             | 1410             | 1508             |
| E | 556             | 603              | 705              | 756              |
| F | 184             | 203              | 203              | 203              |
| G | 762             | 800              | 1000             | 1102             |
| H | 298             | 279              | 298              | 283              |
| I | 1613            | 1426             | 1499             | 1426             |
| J | 1429            | 1241             | 1318             | 1241             |
| K | 629             | 479              | 616              | 479              |
| L | 886             | 984              | 1181             | 1299             |
| M | 619             | 378              | 540              | 403              |
| N | 772             | 870              | 1070             | 1184             |
| O | 700             | 752              |                  |                  |
| P | 378             | 340              | 368              | 308              |
| Q | 464             | 511              | 610              | 660              |
| R | 327             | 344              | 400              | 419              |
| S | 930             | 743              | 822              | 743              |
| T | 152             | 152              | 152              | 152              |
| U | 48              | 48               | 48               | 48               |
| V | 394             | 302              | 371              | 308              |
| W | 397             | 302              | 371              | 308              |
| X | 397             | 440              | 540              | 591              |
| Y | 171             | 171              | 171              | 171              |

## SINGLE SIDED MODELS - OTHER DETAILS

|   | STUV 21 / 95 SF  | STUV 21 / 105 SF   | STUV 21 / 125 SF   | STUV 21 / 135 SF   |
|---|--|--|--|--|
| <b>MATERIAL</b>                                 | Steel, ceramic bricks, glass, galvanised steel, rockwool | Steel, ceramic bricks, glass, galvanised steel, rockwool | Steel, ceramic bricks, glass, galvanised steel, rockwool | Steel, ceramic bricks, glass, galvanised steel, rockwool |
| <b>OUTPUT KW</b>                                | 10kw to 18kw   | 7kw to 19kw  | 11kw to 23kw   | 11kw to 21kw   |
| <b>HEATING CAPACITY</b>                         | 120m <sup>2</sup>  | 125m <sup>2</sup>  | 145m <sup>2</sup>  | 130m <sup>2</sup>  |
| <b>MINIMUM FLUE HEIGHT</b>                      | 4.5m   | 4.5m   | 4.5m   | 4.5m   |
| <b>WEIGHT (excluding zero clearance casing)</b> | 292kg  | 224kg  | 305kg  | 286kg  |
| <b>MAX LOG SIZE</b>                             | 60cm   | 80cm   | 100cm  | 100cm  |
| <b>ACTIVE FLUE SIZE</b>                         | 10"  | 8"   | 10"  | 10"  |

# 2. SPECIFICATIONS

## DOUBLE SIDED MODELS WITH ZERO CLEARANCE CASING - DIMENSIONS (mm)

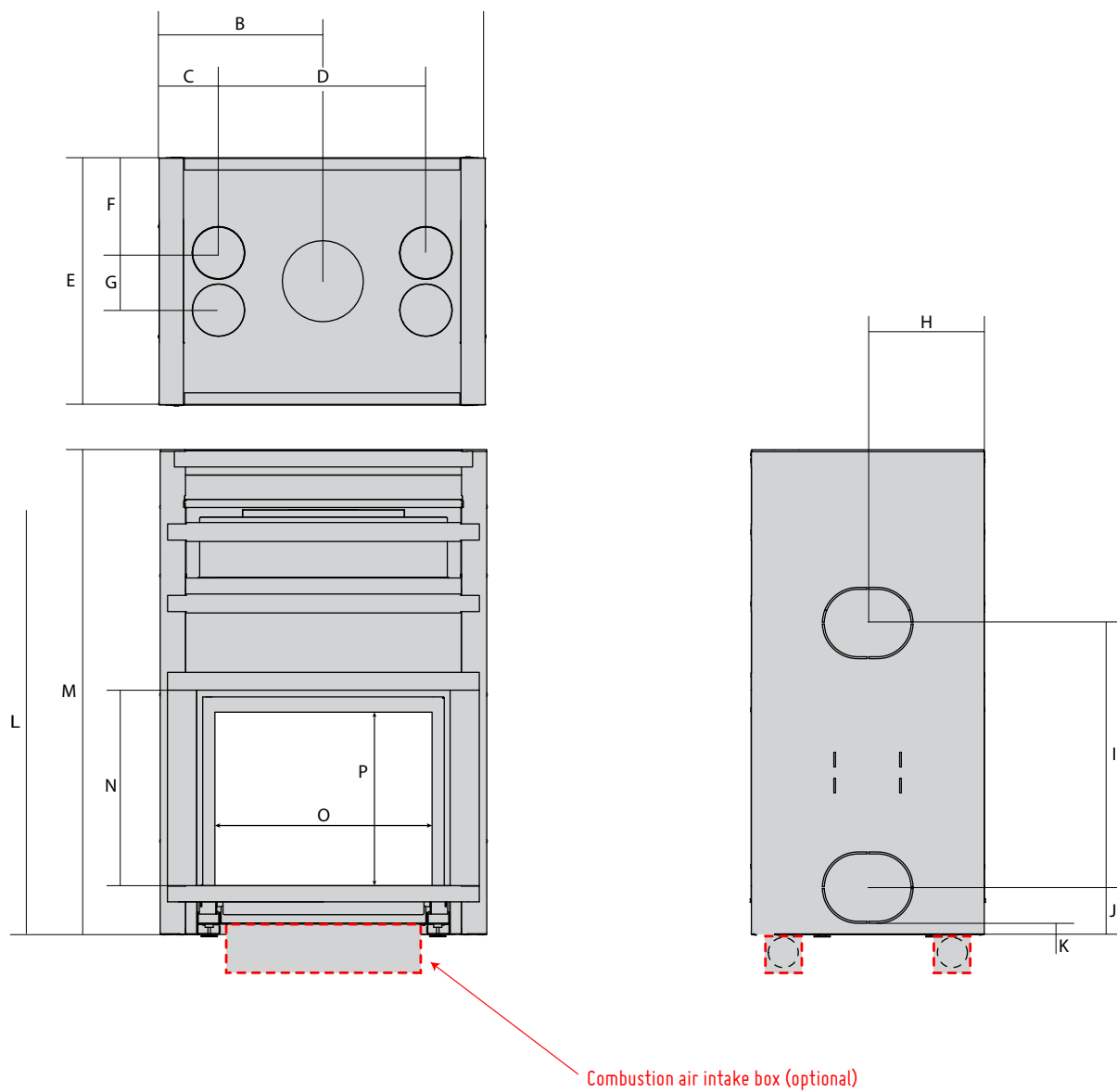

# 2. SPECIFICATIONS

## DOUBLE SIDED MODELS WITH ZERO CLEARANCE CASING- DIMENSIONS (mm)

|   | STUV 21 / 95 DF | STUV 21 / 125 DF |
|---|-----------------|------------------|
| A | 1108            | 1410             |
| B | 556             | 705              |
| C | 184             | 203              |
| D | 762             | 1000             |
| E | 752             | 752              |
| F | 248             | 248              |
| G | 175             | 200              |
| H | 337             | 337              |
| I | 930             | 822              |
| J | 149             | 149              |
| K | 41              | 41               |
| L | 1429            | 1470             |
| M | 1613            | 1499             |
| N | 629             | 616              |
| O | 772             | 1070             |
| P | 619             | 540              |

## DOUBLE SIDED MODELS - OTHER DETAILS

|   | STUV 21 / 95 DF  | STUV 21 / 125 DF   |
|---|--|--|
| <b>MATERIAL</b>                                 | Steel, ceramic bricks, glass, galvanised steel, rockwool | Steel, ceramic bricks, glass, galvanised steel, rockwool |
| <b>OUTPUT KW</b>                                | 12kw to 27kw   | 14kw to 27kw   |
| <b>HEATING CAPACITY</b>                         | 165m <sup>2</sup>  | 165m <sup>2</sup>  |
| <b>MINIMUM FLUE HEIGHT</b>                      | 4.5m   | 4.5m   |
| <b>WEIGHT (excluding zero clearance casing)</b> | 297kg  | 310kg  |
| <b>MAX LOG SIZE</b>                             | 70cm   | 100cm  |
| <b>ACTIVE FLUE SIZE</b>                         | 12"  | 12"  |

# 2. SPECIFICATIONS

## SINGLE SIDED MODELS WITHOUT CLEARANCE CASING - DIMENSIONS (mm)

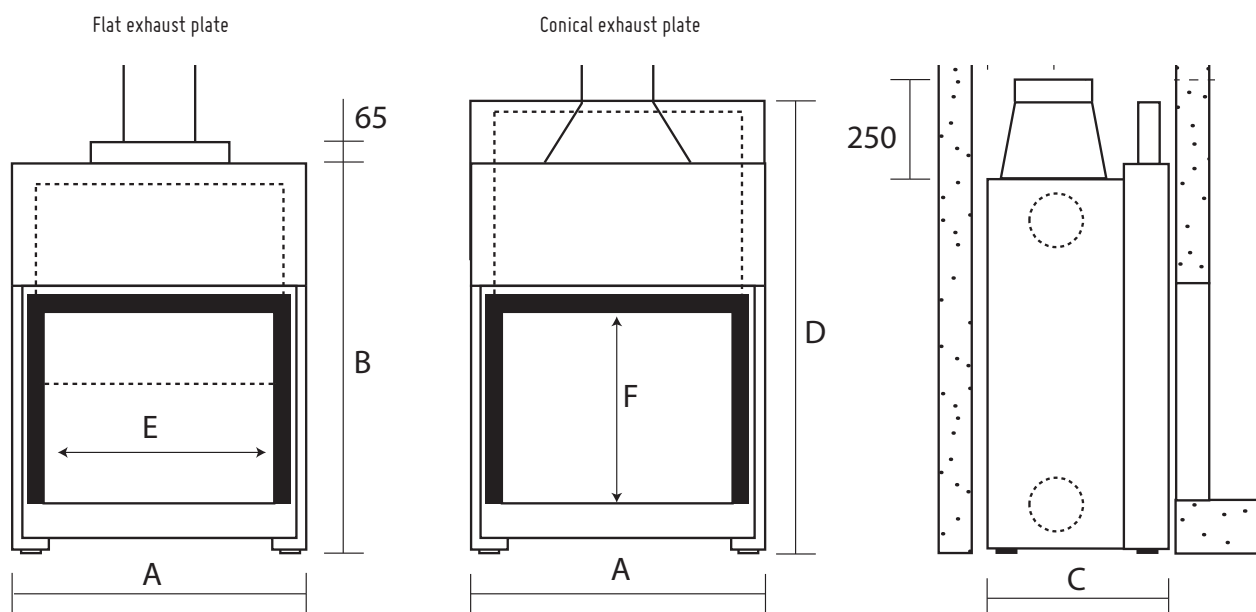

## SINGLE SIDED MODELS WITHOUT ZERO CLEARANCE CASING - DIMENSIONS (mm)

|   | STUV 21 / 95 SF | STUV 21 / 105 SF | STUV 21 / 125 SF | STUV 21 / 135 SF |
|---|-----------------|------------------|------------------|------------------|
| A | 950             | 1050             | 1250             | 1350             |
| B | 1225            | 1040             | 1115             | 1040             |
| C | 590             | 496              | 563              | 500              |
| D | 1455            |                  | 1295             |                  |
| E | 770             | 870              | 1070             | 1170             |
| F | 615             | 400              | 535              | 400              |

# 2. SPECIFICATIONS

## DOUBLE SIDED MODELS WITHOUT CLEARANCE CASING - DIMENSIONS (mm)

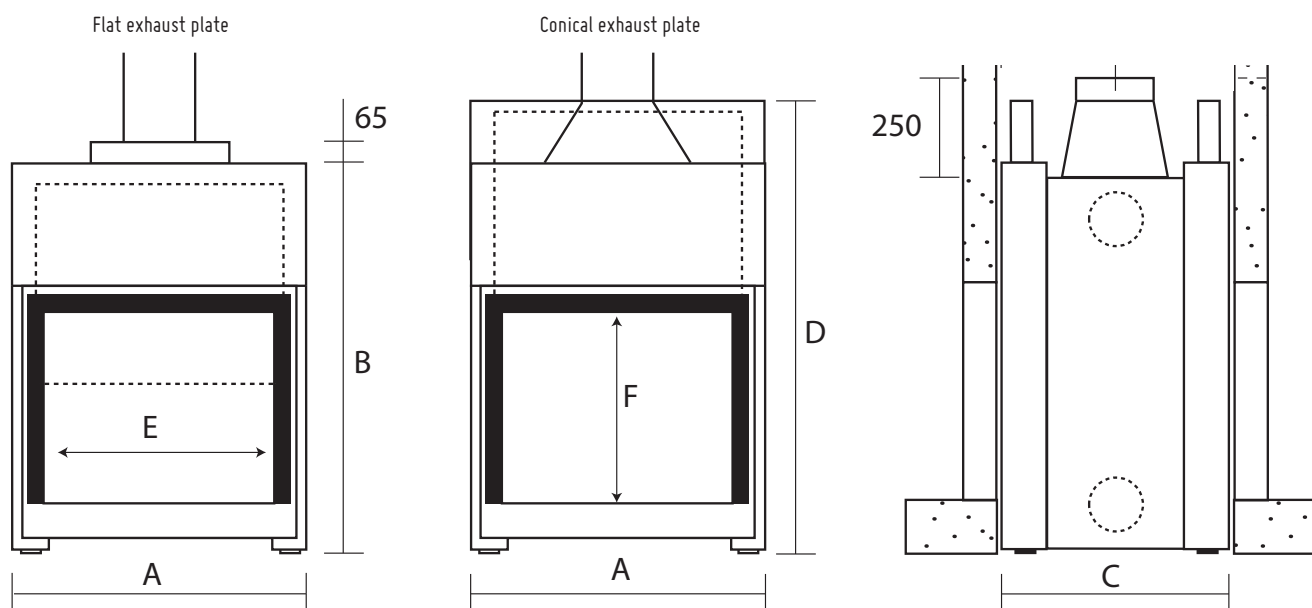

## SINGLE SIDED MODELS WITHOUT ZERO CLEARANCE CASING - DIMENSIONS (mm)

|   | STUV 21 / 95 DF | STUV 21 / 125 DF |
|---|-----------------|------------------|
| A | 950             | 1250             |
| B | 1225            | 1115             |
| C | 670             | 670              |
| D | 1455            | 1295             |
| E | 770             | 1070             |
| F | 615             | 535              |



# 2. SPECIFICATIONS

## EXPLODED DIAGRAM - SINGLE SIDED MODEL (WITH ZERO CLEARANCE CASING)

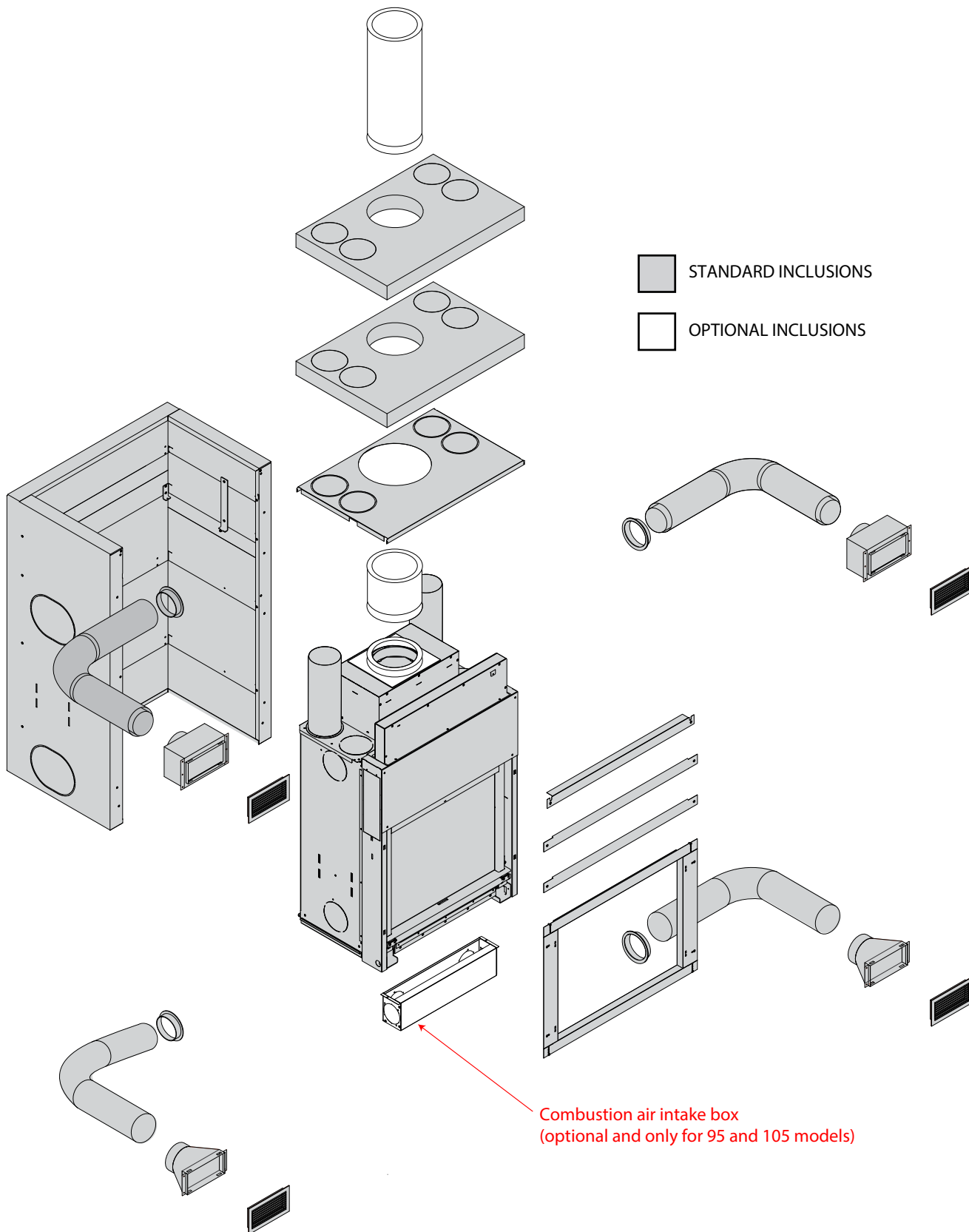

## 3. CLEARANCES

When installed on a floor made from combustible material, the appliance and enclosure must sit on a raised platform consisting of a non-combustible framework, no less than 150mm high with a solid 18mm non-combustible top (minimum). The raised platform must be at least the same width and depth of the appliance (including the zero clearance box). The fireplace height can then be adjusted as desired using the adjustable feet. (Fig A)

When installed on a non combustible floor the fireplace can be installed directly onto the floor and adjusted in height using the adjustable feet. (Fig B)

In situations with combustible walls and when using the insulating casing the sides and rear wall of the enclosure shall be no closer than 150mm to the appliance. (Fig A, B, C & D)

In situations with non combustible walls (brickwork or Silca boards) the sides and rear wall of the enclosure shall be no closer than 50mm to the appliance. There is no need to use the insulating casing in such situations. (Fig E, F, G & H)

Only non-combustible material shall be used on the front wall of the enclosure.

All internal framework above the appliance shall be made of non-combustible material.

When using the insulating casing a 40mm thick Silca board matching the width and depth of the appliance must be fitted to the top of the appliance to stop heat transfer onto the ceiling and walls. (Fig A & B)

The cavity above the appliance must not be capped and must have a minimum of 2500cm<sup>2</sup> of venting. (Fig C & D)

The appliance must be fitted with the specially designed Stuv 21 four casing flue kit.

The appliance must be fitted with a minimum of two heat transfer ducts and two room air inlet ducts.

In situations with non combustible walls and when the insulating casing is not used a cavity lid made using 40mm Silca board is required to sit 600mm above the appliance and no less than 300mm below the combustible ceiling. (Fig E, F, G & H)

To conform with the requirement of the joint AS/NZS 2918:2001 the appliance must be fitted with a minimum two heat transfer ducts and two room air inlet ducts.

# 3. CLEARANCES

## CLEARANCES TO COMBUSTIBLES (USING THE INSULATING CASING)

Figure A: front view (combustible floor)

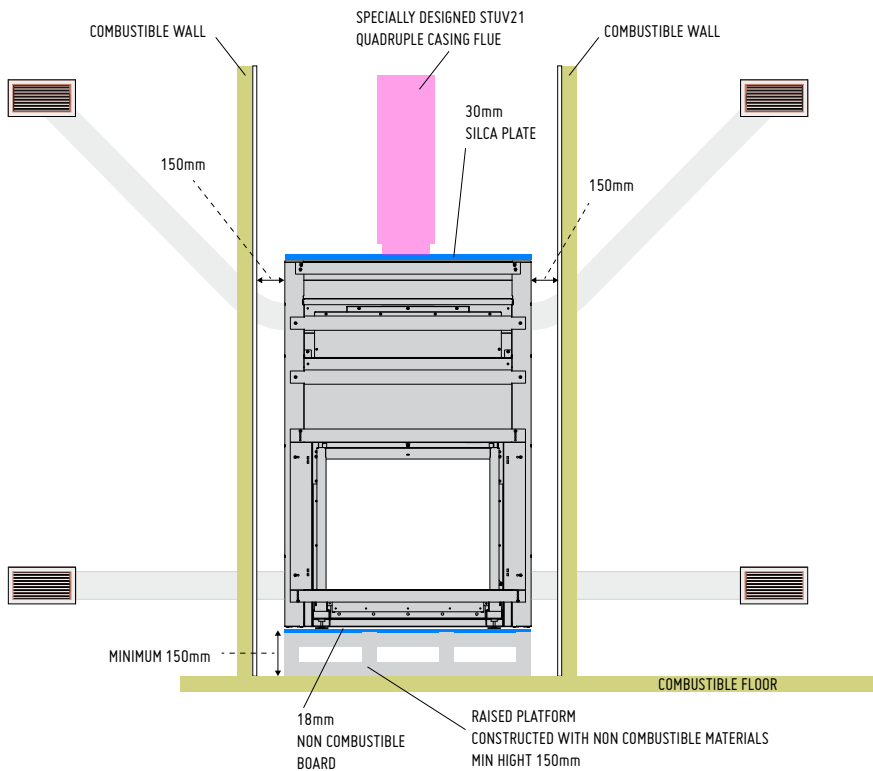
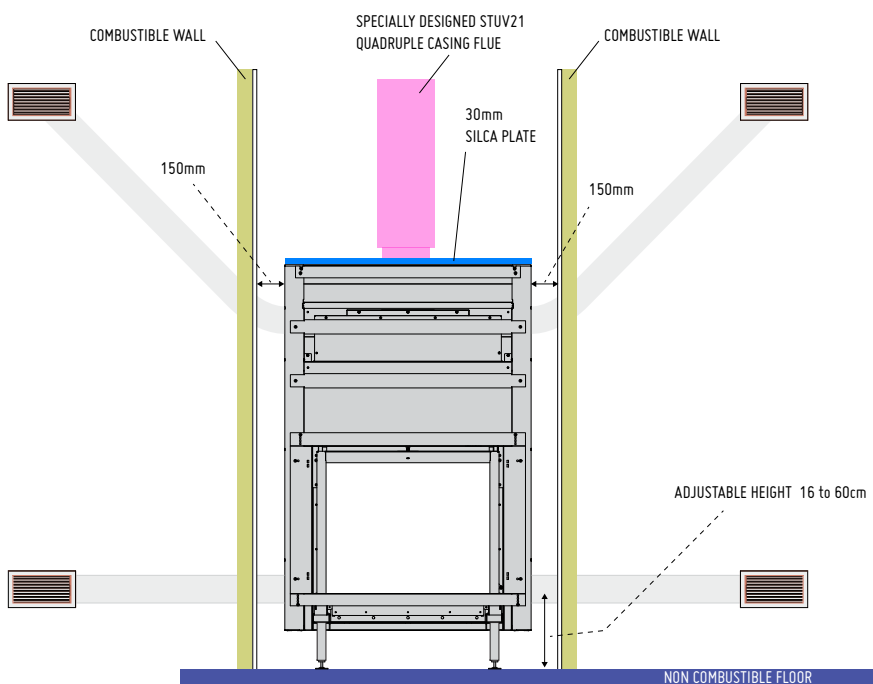

Figure B: front view (non combustible floor)



# 3. CLEARANCES

## CLEARANCES TO COMBUSTIBLES (USING THE ZERO CLEARANCE CASING)

Figure C: side and top views (combustible floor)

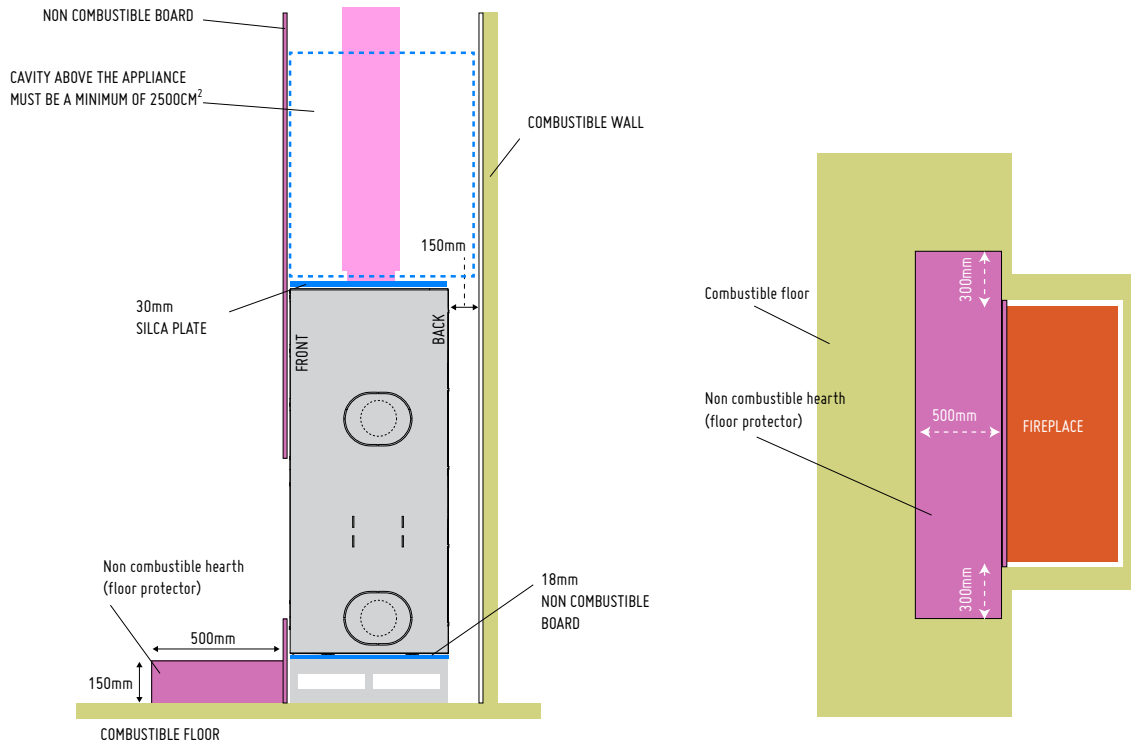
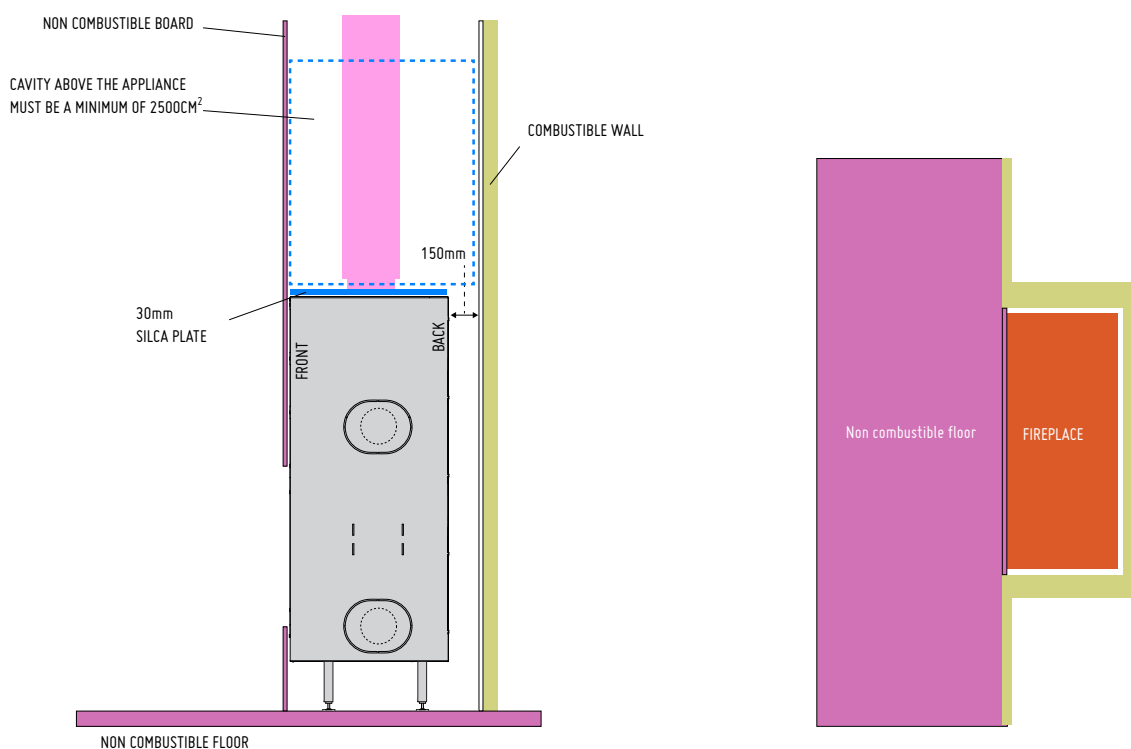

Figure D: side and top views (non combustible floor)



# 3. CLEARANCES

## CLEARANCES TO MASONRY (NO ZERO CLEARANCE CASING)

Figure E: front view

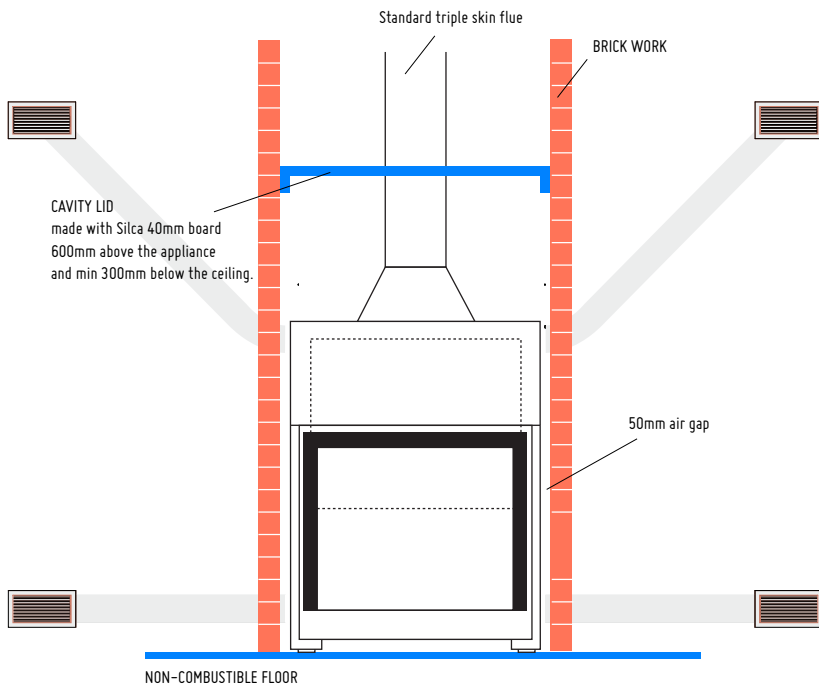
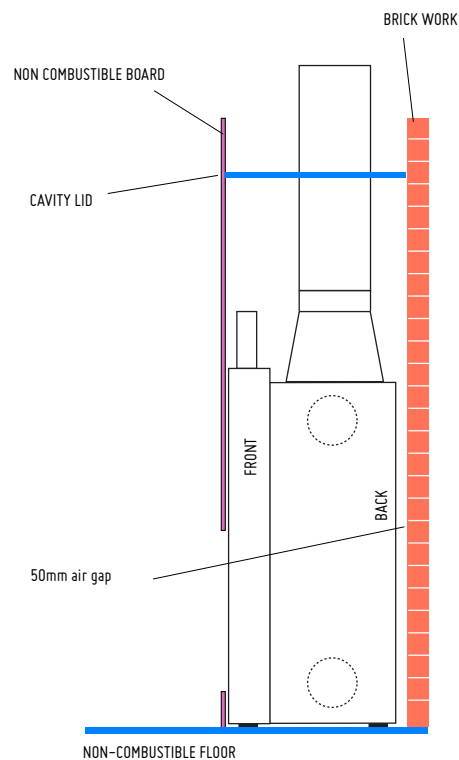

Figure F: side view



# 3. CLEARANCES

## CLEARANCES TO SILICATE BOARD (NO ZERO CLEARANCE CASING)

Figure G: front view

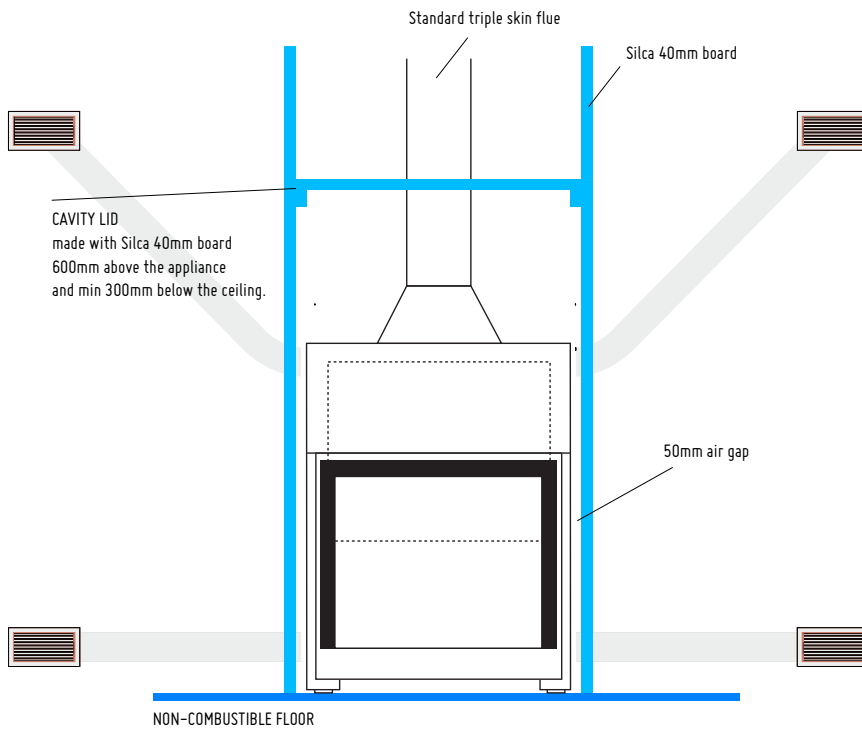
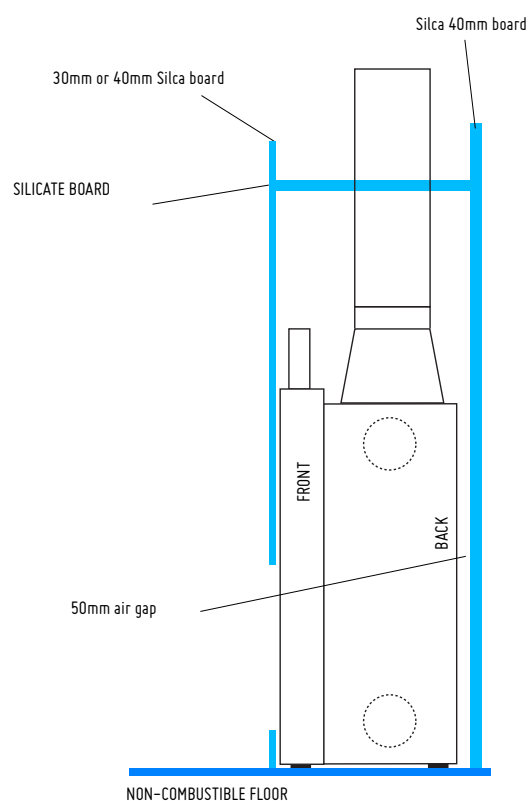
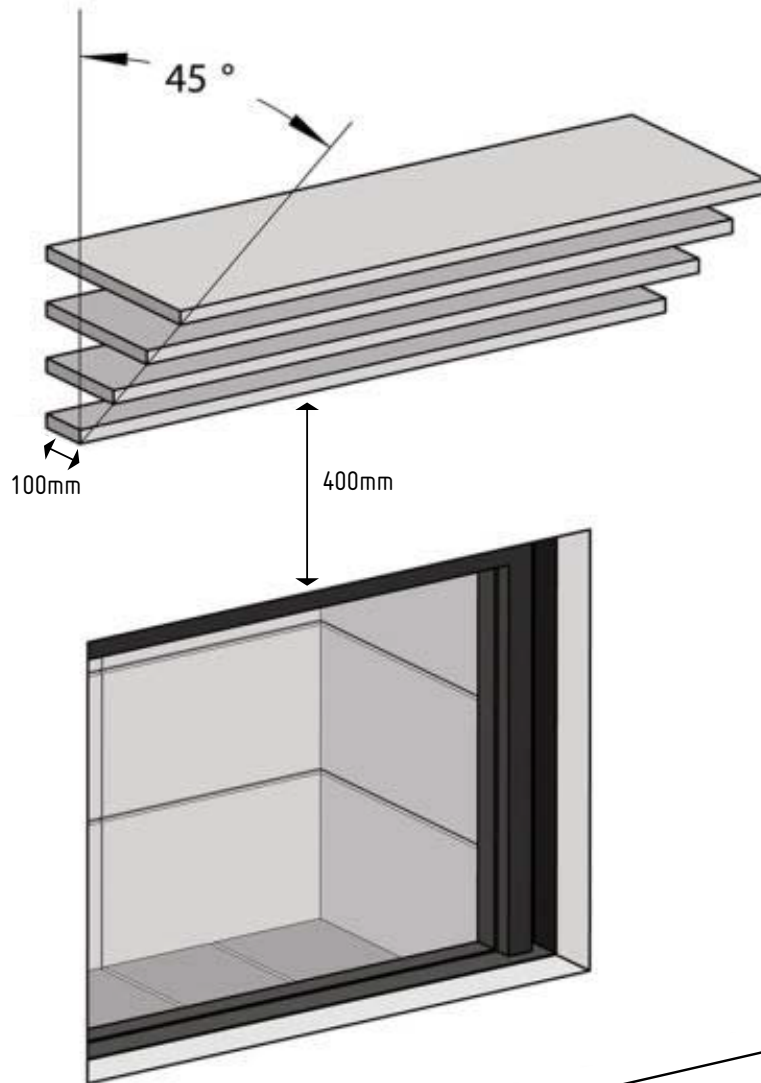

Figure H: side view



# 3. CLEARANCES

## COMBUSTIBLE SHELF



# 4. CONVECTION

Convection air inlets are through single wall flexible ducts.

Convection air outlets must be through insulated double wall ducts.

It is important that the air flow is continuous. It is therefore forbidden to remove the air from a room and send it to another airtight room.

Use a minimum of 2 fresh air inlets and 2 hot air outlets.

The distance between the ceiling and the center of the hot convection grill must be at least 35cm.

The horizontal distance between the hot air convection grill and the appliance cannot be greater than 3m.

The vertical distance between the hot air convection grill and the appliance is not limited.

**See fig I and J.**

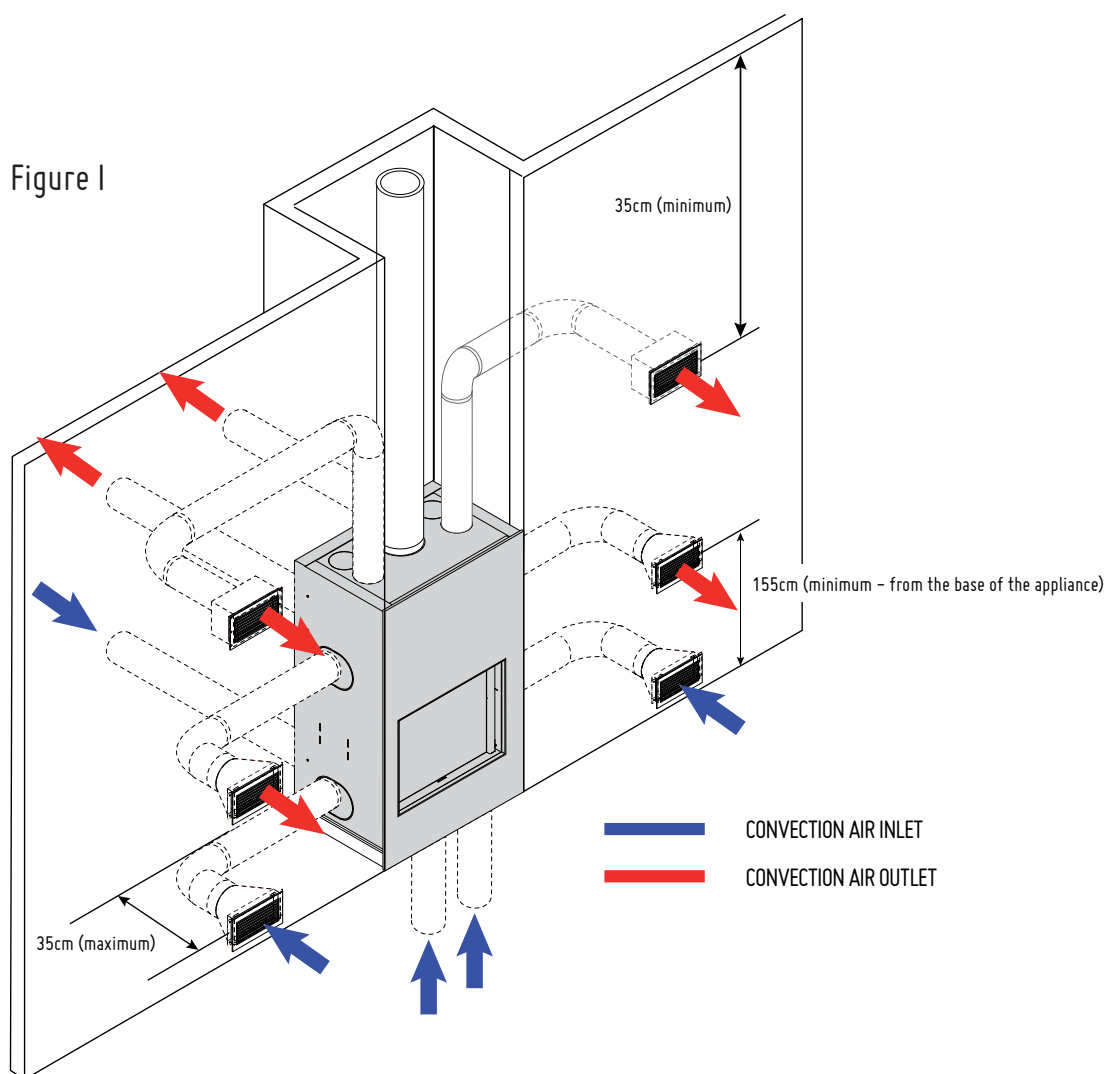



# 4. CONVECTION

## HOT AIR OUTLETS

Figure J

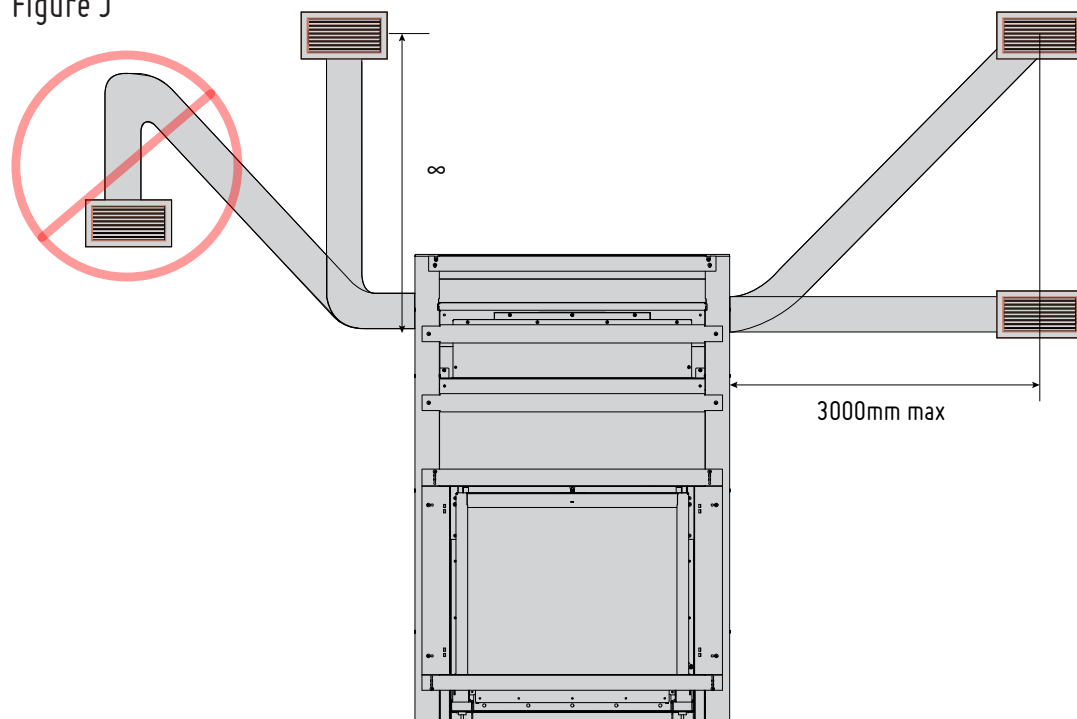

## CONVECTION AIR CIRCULATION

The convection air never comes into contact with the fire. The convection is an independent air channel. The air circulates around the combustion chamber, gets hot and goes out through convection grates in the same room or in other rooms.

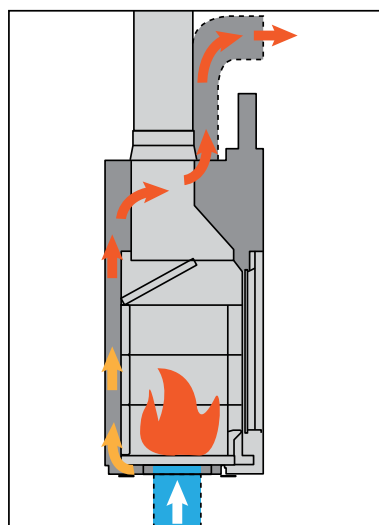

CONVECTION AIR CIRCULATION

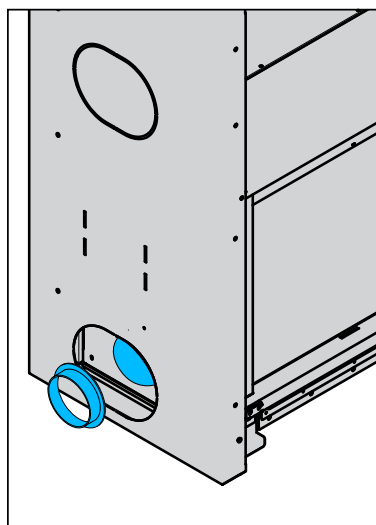

CONVECTION AIR INLET

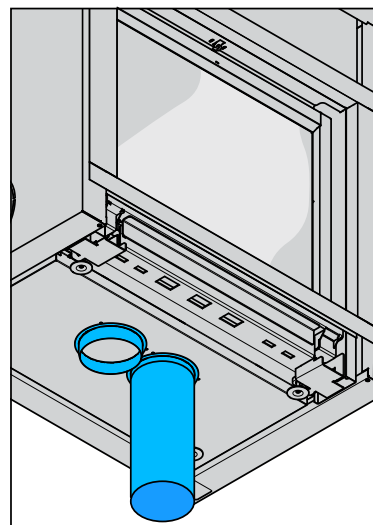

CONVECTION AIR INLET

# 5. COMBUSTION

When operating with an open fire, the Stuv 21 consumes a large amount of air. Therefore, we recommend providing an external air supply, although this is not mandatory.

A sufficient air inlet must be created under the stove, at the front. When not using the air intake box with connected duct, the base of the fire must be supplied with fresh air. The fresh air must come from a ventilated empty space, a ventilated room or from outside the house (mandatory for passive/air tight buildings). ONLY DUCT THE FRESH AIR INLET TO THE APPLIANCE USING THE INTAKE BOX.

The air intake, which varies depending on the model, should ideally be located beneath the front of the unit and incorporate a shut-off register (fig a).

Ideally the fresh air inlet would be fitted with a closure valve (fig e and f) to prevent the room from becoming cold when the appliance is not in use. It should ideally be located as close as possible to the outside wall and controlled from inside the room.

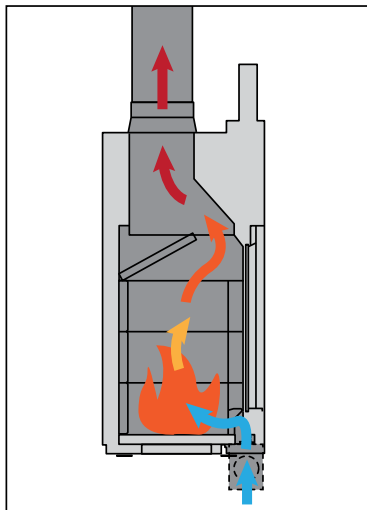

a. COMBUSTION AIR CIRCULATION

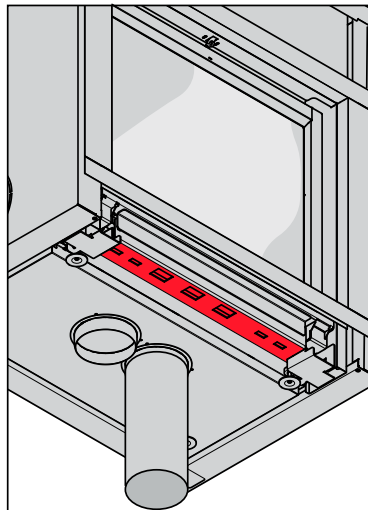

b. COMBUSTION AIR INLET

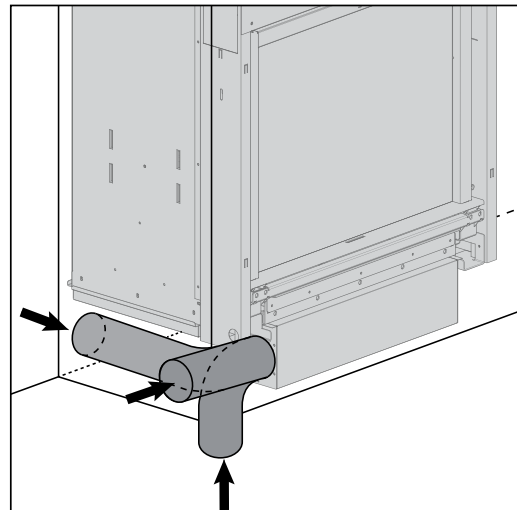

c. COMBUSTION AIR INLET WITH DUCTED INTAKE BOX

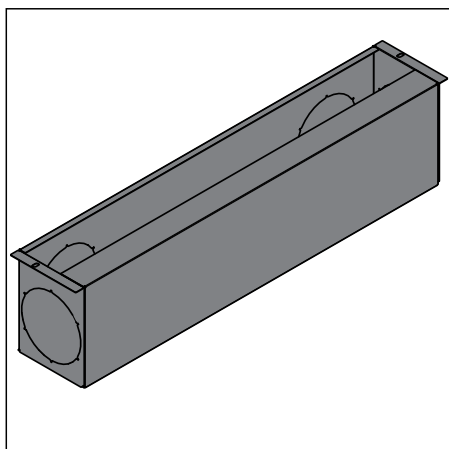

d. COMBUSTION AIR INTAKE BOX

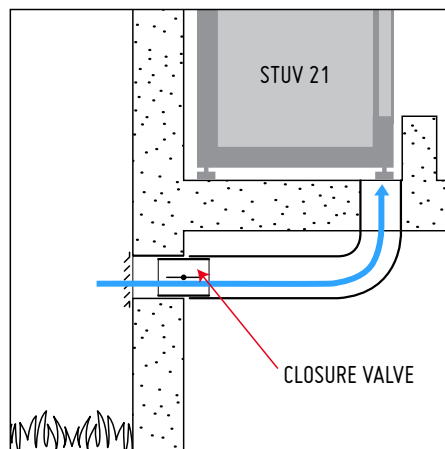

e. EXTERNAL COMBUSTION AIR INTAKE



f. EXTERNAL COMBUSTION AIR INTAKE

# 5. COMBUSTION

## COMBUSTION AIR INLET

|                  | INLET DIAMETER |
|------------------|----------------|
| STUV 21 / 95 SF  | 6 inches       |
| STUV 21 / 105 SF | 6 inches       |
| STUV 21 / 125 SF | 6 inches       |
| STUV 21 / 135 SF | 6 inches       |
| STUV 21 / 95 DF  | 6 inches       |
| STUV 21 / 125 DF | 6 inches       |

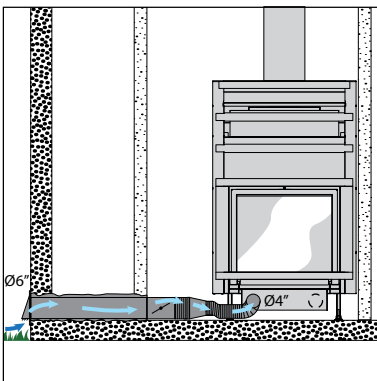

EXTERNAL COMBUSTION AIR (INTAKE BOX)

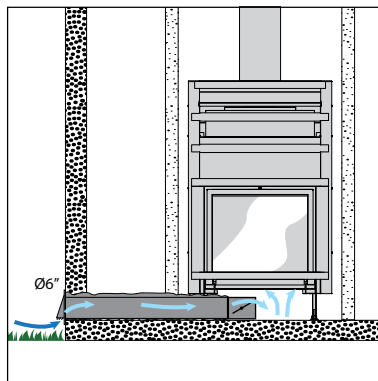

EXTERNAL COMBUSTION AIR (NO INTAKE BOX)

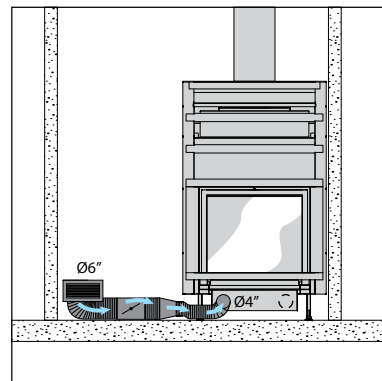

INTERNAL COMBUSTION AIR (INTAKE BOX)

# 6. TEST REPORT

## TEST REPORT NO ASFT18044 (PRELIMINARY REPORT)

|                               |   |
|-------------------------------|---|
| <b>TESTING LABORATORY:</b>    | Australian Solid Fuel Testing             |
| <b>MANUFACTURER:</b>          | Stuv                                      |
| <b>MODEL:</b>                 | Stuv 21                                   |
| <b>WORK REQUESTED:</b>        | Compliance with AS/NZS2918:2001 Standards |
| <b>ISSUE DATE:</b>            | 4/05/2018                                 |
| <b>INVESTIGATING OFFICER:</b> | Steve Marland                             |

### **CONCLUSION:**

The Stuv 21 Inbuilt appliance installed with a triple skin flue system, conforms to the requirements of Australian/New Zealand Standard 2918:2001, with respect to floor, side wall and rear wall surface temperatures, when tested in the test position shown in p11, p14 and 15p of this report in accordance with Appendix B of AS/NZS2918;2001.

# 7. OPERATION

## What you should burn

- Untreated, air dried hardwood
- Split logs with a humidity content of less than 20%

## Do not burn

- Trash
- Painted plastic
- Coated or preservative treated wood
- Waste or black coal
- Inflammable liquids
- Fire gels
- Moist wood with a residual humidity content of more than 20% (this may cause sooting of the chimney).

### **WARNING:**

- Do not use flammable liquids or aerosols to start or rekindle the fire.
- Do not use flammable liquids or aerosols in the vicinity of the fireplace when operating.
- Do not store fuel within prescribed installation clearance distances.
- The use of some types of preservative-treated woods as a fuel can be hazardous.
- Misuse may lead to unhealthy and environmentally harmful emissions and will void any warranty or guarantee.
- Burning only seasoned hardwood helps to protect the environment and lower emissions.